

Curaflex® 3000

against pressing or non-pressing water

- opening for penetrations
- for buildings **yet to be constructed**
- for **waterproof concrete** (white tank)

Pipe sleeves



Product benefits

- homogeneous connection to concrete, reinforced by special grooving
- optimally developed inner wall for the reception of Curaflex® gasket inserts
- with a white tank (waterproof concrete structures without tanking membranes/thick-coatings)



Technical details

- gas-tight with optional coating of the pipe sleeve inside and front surface
- can be combined with all Curaflex® gasket inserts

Material:

- asbestos-free fiber cement

Accessories from page 88

pipe outer diameter from - to	NB pipe sleeve [mm]	pipe sleeve diameter D ₂ max. [mm]	standard length L ₁ [mm]
1 - 40	80	140	200 240 250 300 350 365 400 500 650 1000
41 - 57	100	160	
58 - 77	125	165	
78 - 104	150	190	
105 - 145	200	245	
146 - 190	250	300	
191 - 233	300	350	
234 - 288	350	400	
289 - 339	400	470	
340 - 380	450	520	
381 - 430	500	570	
431 - 530	600	680	
531 - 620	700	800	

We supply pipe sleeves in more sizes. Talk to us.

Variant:

Curaflex® pipe sleeve 3000/T
longitudinally split version. For
installations with existing pipeline in the wall

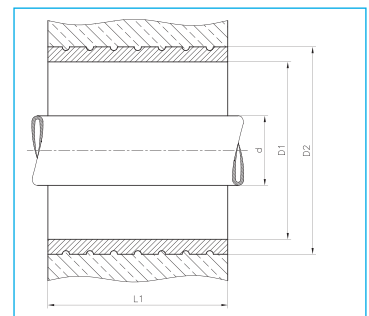
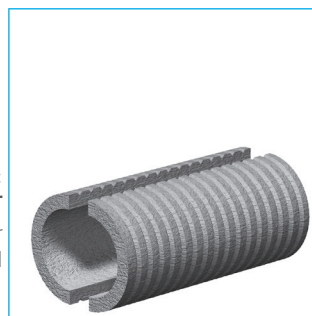

Service
Sealing
Solutions Ltd

For more information, please call us on 01952 510050
or email sales@servicesealingsolutions.co.uk